

## **ST-8100 SERIES**

# **ASSEMBLY INSTRUCTIONS**

ALL DRAWINGS ARE FOR ILLUSTRATION ONLY.

# Assembly Instructions Include:

- Step 1 ..... Site Preparation
- Step 2 ..... Leg Assembly
- Step 3 ..... Setting the Stage (Non-Telescoping Legs)
- Steps 4-6 ..... Setting the Stage

- Step 7 ..... Guard Rail Installation
- Step 8 ..... Diagonal Bracing
- Step 9 ..... Stairs
- Special Configurations Sections

## STEP 1 Site Preparation

- A. Determine the exact location of the stage.
- B. For outdoor stages, mudsills are recommended to distribute the weight (150 PSF) on the legs. This will help prevent the legs from sinking and ease in leveling the stage.

## STEP 2 Leg Assembly

Attach adjustable rubber base pad to galvanized legs in 3rd hole with 2" snap pins.

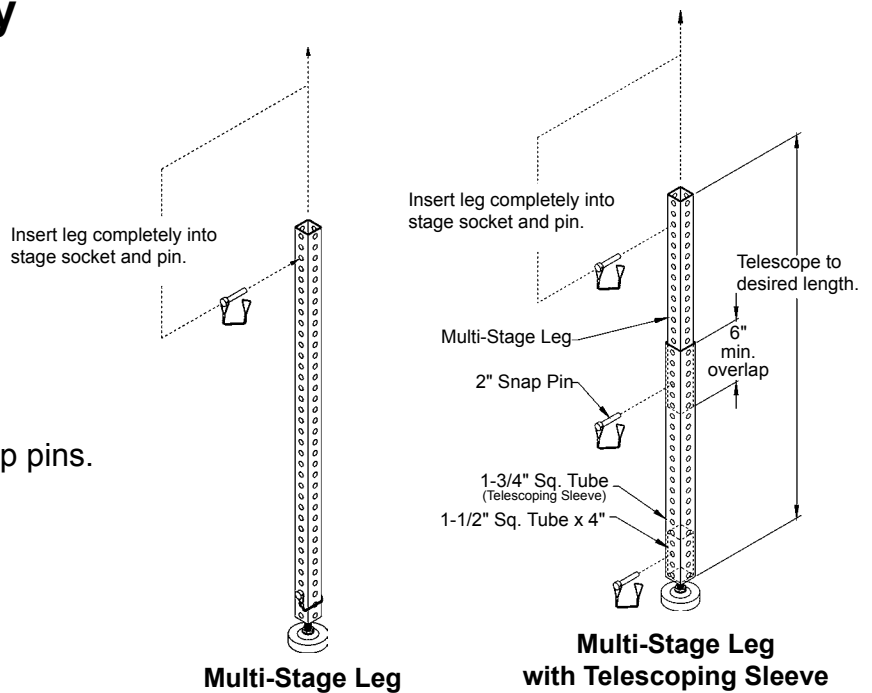

## STEP 3 Setting the Stage (Non-Telescoping Legs)

- A. Insert legs completely into all four corner sockets in first stage section using 2" snap pins.  
Note: The head of the snap pin should face the outside of deck.
- B. Set first section in back left-hand corner of stage area.  
(any corner may be used as starting point\*)
- C. Align the stage section so that the studs are to the inside and the slotted sides are to the outside of the stage area.

\* Any corner may be used when using the 4' x 4' decks exclusively.

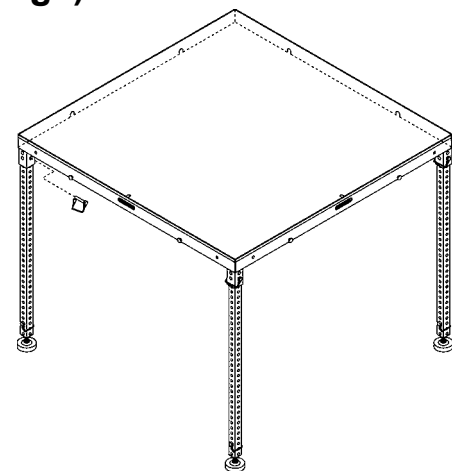

## STEP 4

(Only two galvanized legs are needed on each stage section in this row.)

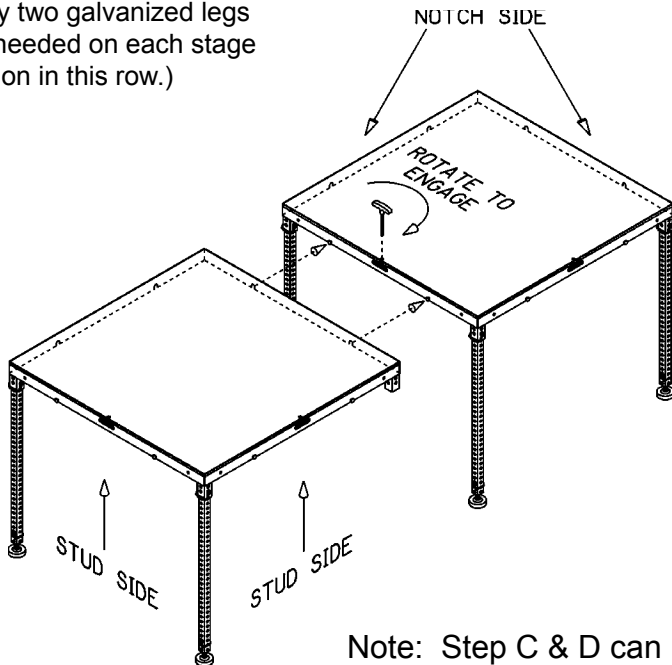

- Set back row of stage sections first.
- Insert the two legs into stage sections as shown and attach it to previous section by means of the slot and pin connections.
- Insert 5/16" T-handle hex wrench through the top of the deck and lock stages together by rotating the cam lock clockwise.
- Insert a plastic plug into the stage deck to cover the cam lock hole as shown.

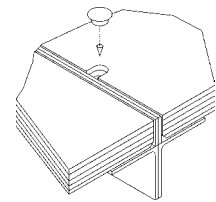

Note: Step C & D can be done as you are setting up the stage or when assembly is completed.

## STEP 5

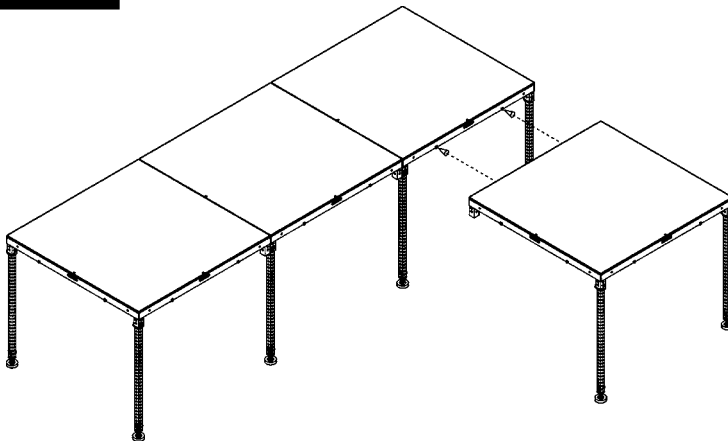

Upon completion of the back row, begin the second row with one section and two legs as shown in Step 4- B, C & D.

## STEP 6

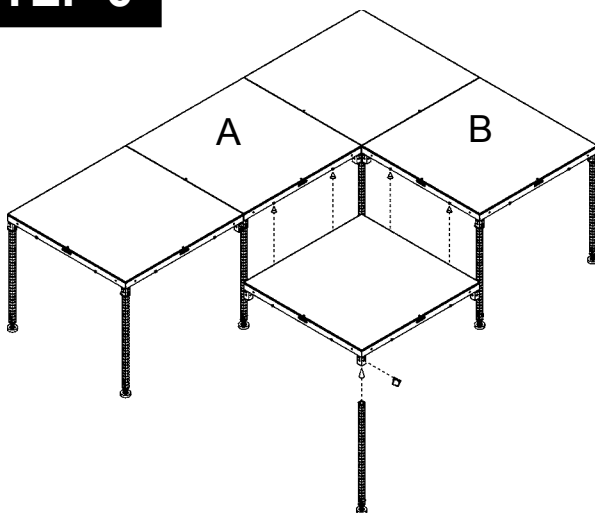

- To continue the second row, insert one leg in corner socket as shown and pin. Attach section to adjacent sections A & B as shown.
- Additional stage sections in each row are assembled in a like manner.
- Decks should be locked together with cam lock (see Step 4, C & D).

## STEP 7 Guard Rail Installation

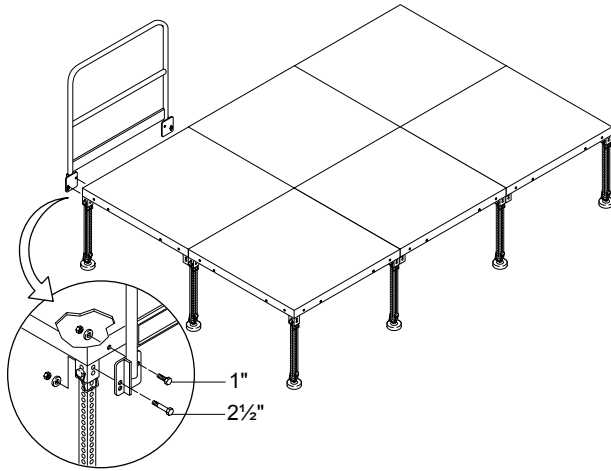

### Panel Guard Installation

- A. Use 1" long bolt to bolt the guard rail to the side of the stage and use 2-1/2" long bolt to bolt the guard rail to the leg of the stage.

### Post and Rail Installation

- A. Select appropriate legs and attach each guard rail post with (2)-3/8" x 2-1/2" hex bolts and nuts directly below the deck sockets as shown in installation options #1 - #4 below.
- B. Posts will be spaced at 4' or 8' intervals depending on rail lengths. Attach mid-rails with 1/2" wing nuts and top rails with 1/2" black rail knobs. (Pre-set all posts and rails before tightening.)

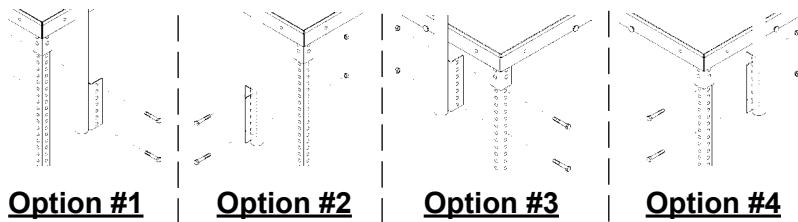
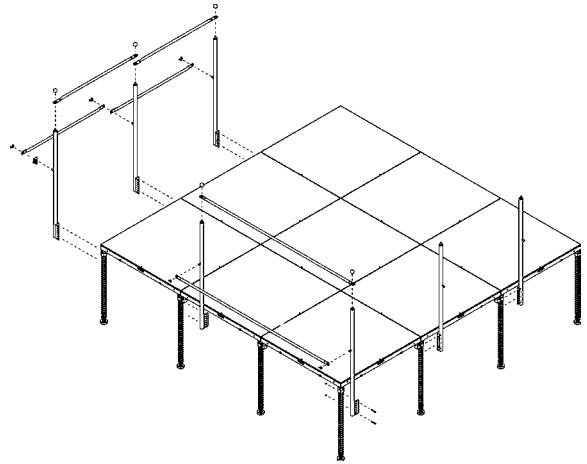

### Guard Rail Post Installation

**NOTE:** Installing guard railing often requires pre-planning. The options shown are the positions that the guard rail post can be bolted to the stage leg.

## STEP 8 Diagonal Bracing

- A. Diagonal bracing is required on stages with heights over 30". Brace each corner and every third bay along each side. Use 3/8 x 2-1/2" hex bolts and wing nuts. Internal braces should be placed in the same row as perimeter bracing.
- B. Double diagonal bracing should be used on heights over 48". At least one of the braces should span the connection between the 1-1/2" leg and the 1-3/4" telescoping sleeve.
- C. The bolt space of the diagonal braces will be:  
12" with legs at 48" center line.  
18" with legs at 46" center line.
- Position braces on leg height to maintain equal brace spacing.

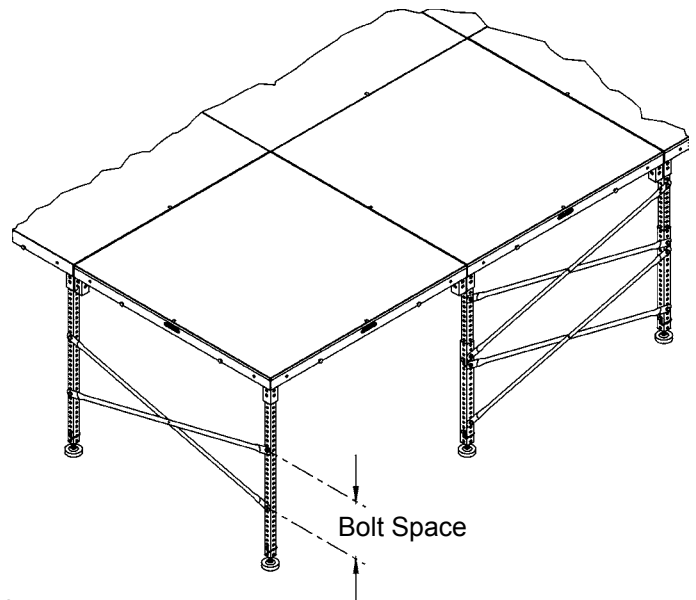

## STEP 8

D. When bracing the Multi-Stage, a common leg should be braced in both directions as shown.

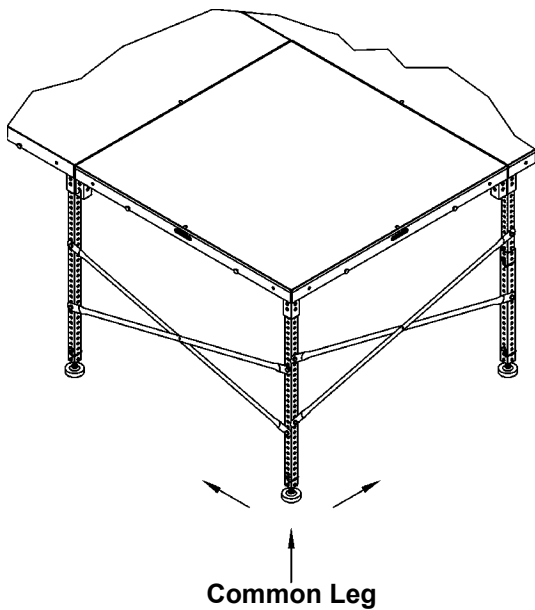

E. Multi-Stage should be braced every 2-3 decks as shown when bracing is required. (Note the common leg bracing method is shown below.)

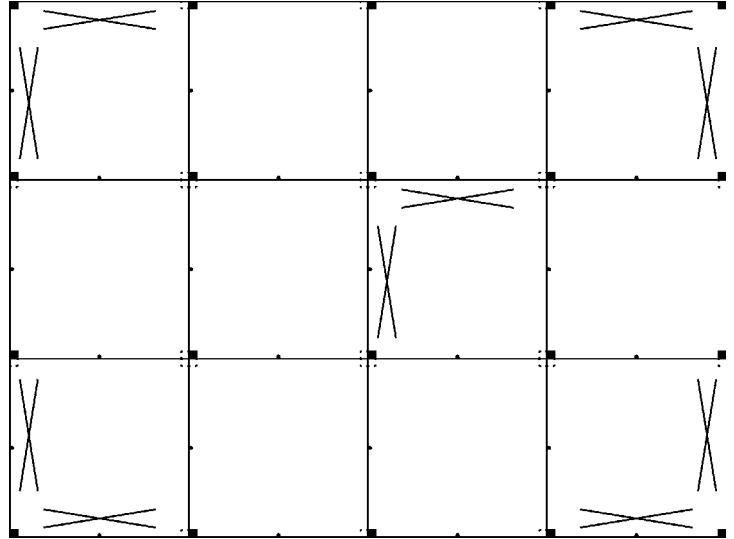

## STEP 9 Stairs

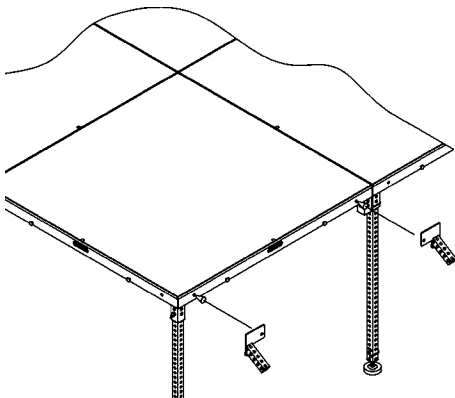

Bolt each bracket in place with the following hardware:

- A. (1) 3/8" x 1" long hex bolt
- (1) 3/8" lock washer
- (1) 3/8" hex nut
- B. (1) 3/8" x 2-1/2" long hex bolt
- (1) 3/8" lock washer

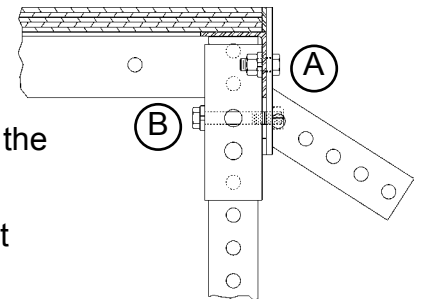

Assemble foot bracket to each leg using the following:

- (1) 3/8" x 2-1/2" long hex bolt
- (1) 3/8" lock washer
- (1) 3/8" hex nut

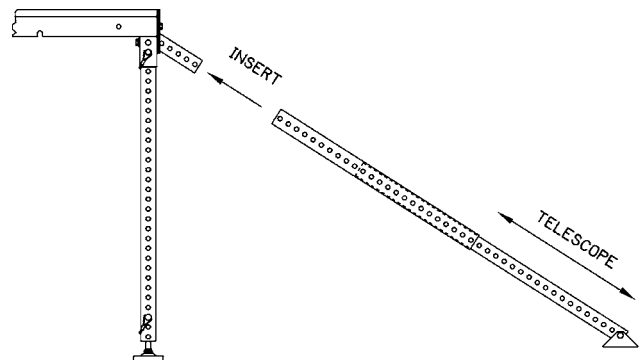
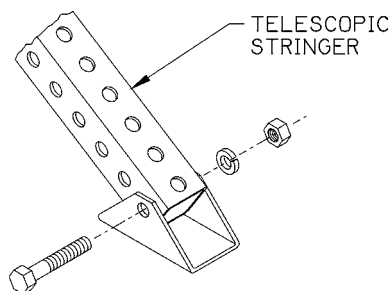

Extend stringer to required length and bolt temporarily until steps are assembled.

# STEP 9

Assemble step as shown with edge to accept optional striping toward the front. (Striping not included.) Parts required to assemble one step are as follows:

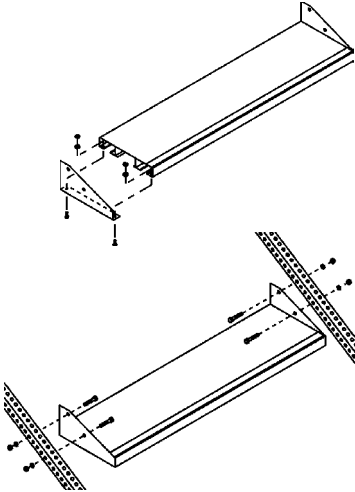

- (1) End plank bracket - right
- (1) End plank bracket - left
- (1) 44" Aluminum step plank
- (4) 1/4" x 3/4" long hex bolt
- (4) 1/4" hex nut
- (4) 1/4" lock washer

Assemble the step to the stringer as shown using the following hardware:

- (4) 3/8" x 2-1/2" long hex bolt
- (4) 3/8" hex nut
- (4) 3/8" lock washer

Assemble handrail stiffener (3-4 ft. package and 4-6 ft. models only) centrally locating it between the handrail support posts on the 3' - 4' stair unit. Place them (2 pcs.) as near as possible to the handrail support posts on the 4' - 6' stair units.

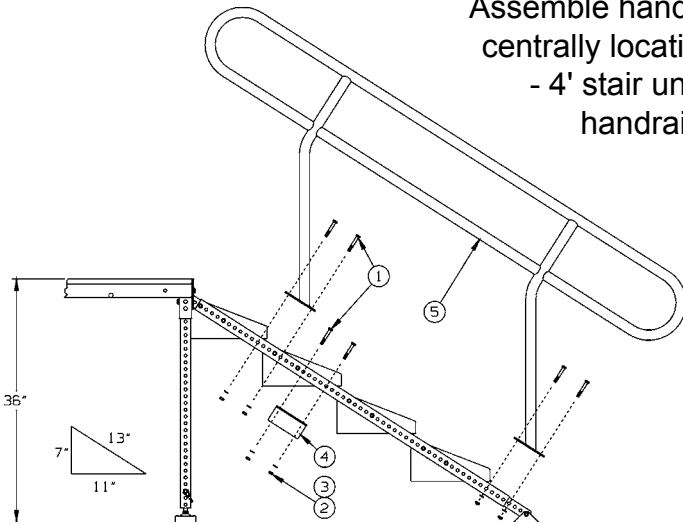

- 1. 3/8" x 2-1/2" long hex bolt
- 2. 3/8" hex nut
- 3. 3/8" lock washer
- 4. Handrail stiffener (2 pcs. on 4-6 ft. pkg. only)
- 5. Handrail (will vary depending on pkg.)

## Handrail Styles

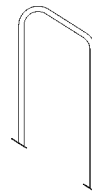

2' - 3' Models

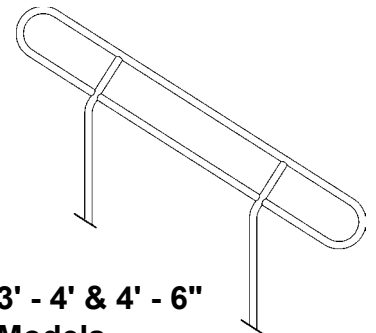

3' - 4' & 4' - 6" Models

Pin support leg (2) to stringer support socket (1) and leveling pad (3). Assemble stringer support socket to the stringer as shown:

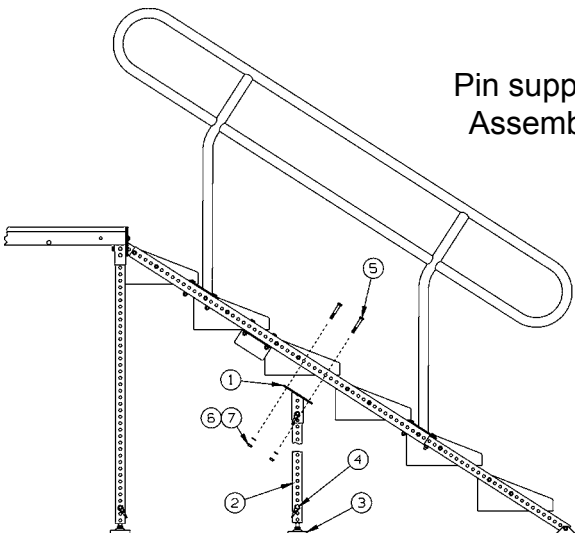

- 1. Stringer support socket (2)
- 2. Support leg (2)
- 3. Adjustable rubber base pad (2)
- 4. 2" snap pin (4)
- 5. 3/8" x 2-1/2" long hex bolt (4)
- 6. 3/8" hex nut (4)
- 7. 3/8" lockwasher (4)

**Note:** The stringer support is included with the 4' - 6' stair unit and is recommended for use on stages over 4' in height.

## STEP 9A Ultra-Stair

- A. Assemble handrail units as shown using bolt (1).
- B. Insert handrail assembly into sockets on stair unit. Fasten with bolts (4) as shown.
- C. Place stair unit onto stage as shown. Secure stair to stage through legs with bolts (6) and under stage with bolts (5).
- D. Adjust height of lowest stair to match rise of other stairs using the adjustable foot pads (7).

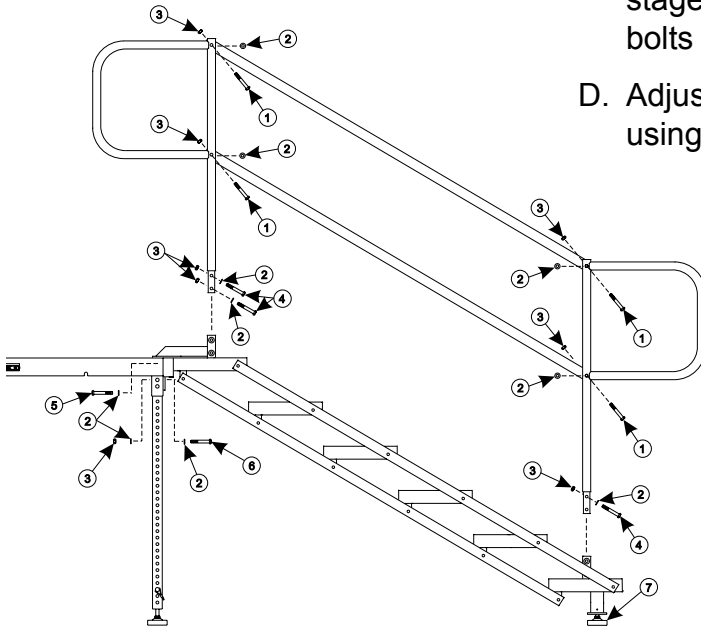

1. Bolt - 3/8-16 x 3-1/2" (8)
2. Flat Washer - 3/8" (20)
3. Lock Nut - 3/8-16 (16)
4. Bolt - 3/8-16 x 2" (6)
5. Bolt - 3/8-16 x 1" (2)
6. Bolt - 3/8-16 x 2-3/4" (2)
7. Rubber Foot Pad (2)

## SPECIAL CONFIGURATIONS

### 45° Stage

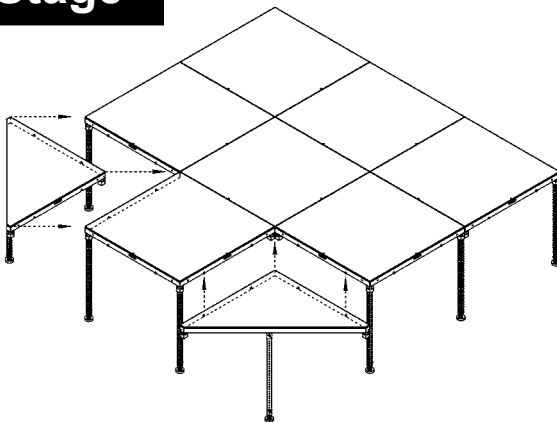

When a 45° stage is mated to the notched side of a deck, bolting is required using:

- (2) 3/8" x 1" hex bolts
- (2) 3/8" hex nuts

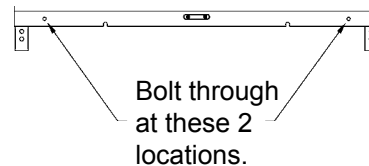

### Riser Assembly with Guard Rail

1. Riser socket
2. 3/8" x 1" long hex bolt
3. 3/8" hex nut

Using a riser application, chair rails w/clamp would be required. Contact factory for details.

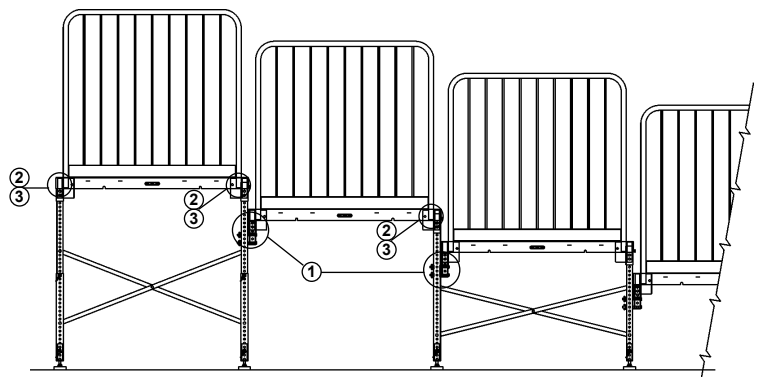

# ADA Access Ramp Assembly with Guard Rail

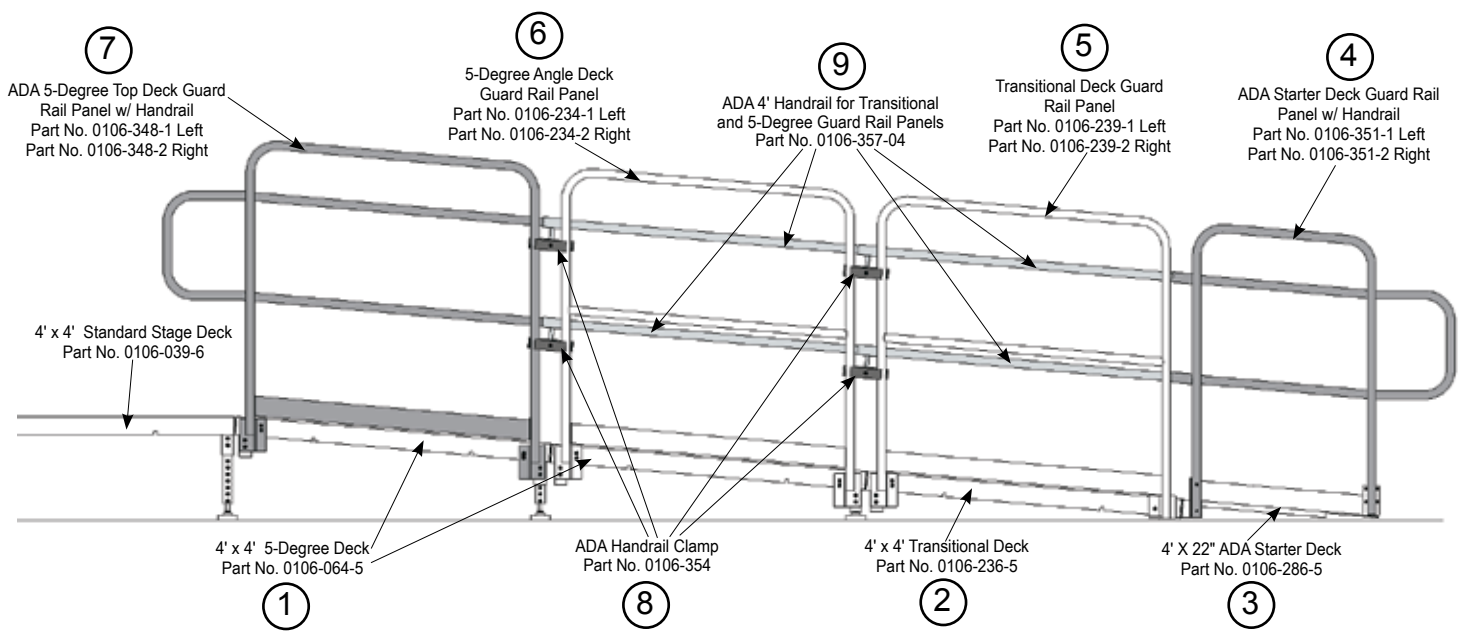

- A. Ramp should be assembled at 5° slope. (1 inch of rise to 12 inches of run)
- B. Ramp should be assembled from platform height to the ground.
- C. Intermediate platform is required when ramp exceeds 30 feet.

1) 4' x 4' 5-Degree Angle Deck .....	0106-064-5
2) 4' x 4' Transitional Deck .....	0106-236-5
3) 4' x 22" ADA Starter Deck.....	0106-286-5
4) ADA Starter Deck Guard Rail Panel.....	0106-351-1 (Left)
with Handrail.....	0106-351-2 (Right)
5) Transitional Deck Guard Rail Panel .....	0106-239-1 (Left)
.....	0106-239-2 (Right)
6) Ramp Deck Guard Rail Panel .....	0106-234-1 (Left)
.....	0106-234-2 (Right)
7) Top Deck Guard Rail Panel with Hand Rail.....	0106-348-1 (Left)
.....	0106-348-2 (Right)
8) ADA Handrail Clamp (to attach Item 9 to Item 5 & 6).....	0106-354
9) ADA Handrail (for Item 5 & 6).....	0106-357-04